



WAYZATA PARKS AND TRAILS BOARD

Meeting Agenda

Wayzata City Hall Community Room, 600 Rice Street
Tuesday, August 12, 2025
6:00 PM

1. **Call to Order and Roll Call**
2. **Approval of Agenda**
3. **Approval of Minutes**
 - a. July 8, 2025 Parks and Trails Board Meeting Minutes
 - b. July 24, 2025 Parks and Trails Board Workshop Minutes
4. **Public Comments**
5. **Old Business**
 - a. Klapprich Park Update
 - b. Wayzata Beach/Shaver Park and Little Beach Master Plan Discussion
 - c. Sunday Music in the Park Concerts Review
6. **New Business**
 - a. CIP Budget Discussion
7. **Other Business**
 - a. Communications Recap
 - b. Staff Updates
 - c. Future Agenda Items
8. **Adjourn**
 - a. Next Meeting - September 17

Members of the Parks & Trails Board and some staff may gather at 6Smith immediately after the meeting for a purely social event. All members of the public are welcome.



Parks and Trails Board Meeting Minutes
Tuesday, July 8, 2025
Wayzata City Hall - Community Room

Attendees: Chair Tory Schalkle, Sarah Showalter, Sarah Randolph, Bianca Jensen, Blake Cameron, and Christian Erard.

Staff: Parks and Environment Planner Nick Kieser, Parks Member Robert Savage, and City Forester Bennett Myhran.

A site visit of Klapprich Park was conducted from 5:30 PM to 6:00 PM prior to the regular Parks and Trails Board meeting.

1. **Call to Order and Roll Call:** Meeting was called to order at 6:00 PM by Chair Schalkle.
2. **Approval of Agenda:** Motion to approve the agenda by Chair Schalkle, seconded by Showalter. Motion approved unanimously.
3. **Approval of Minutes:** Motion to approve minutes by Chair Schalkle, seconded by Cameron. Motion approved unanimously.
4. **Public Comments:** No public comments were provided.
5. **Old Business:**
 - a. **City Hall Park Improvements Discussion:** Staff provided an overview of the proposed 2026 CIP project to construct a pathway on the east side of the library, connecting the Children's Garden to the stairway. A total of \$13,000 is currently allocated for this project in the CIP.

Parks Members, Robert Savage, introduced himself as new to Wayzata's Parks Department, bringing 35 years of experience in landscape work. He highlighted his previous contributions to Heritage Park, Mill Street, and local

cemetery enhancements. Savage expressed a personal commitment to enhancing the library area.

The Board discussed options for improvements to the City Hall park with staff.

Pathway Options:

- Flagstone: Aesthetic match to current park elements; more expensive.
- Aggregate Path Mix: ADA-compliant and cost-effective, similar to the 9/11 Memorial material.
- Design Note: Pathway may wrap around to connect with the existing bench area with less than 2% slope to meet ADA compliance.

Edible Garden Concept:

- Proposed edible and fruit-bearing plantings on both east and west sides of the path.
- Two 50' x 11' beds including raspberries, blackberries, strawberries, asparagus, sunflowers, herbs, and low-height fruit trees.
- Raised herb planters proposed outside library windows to integrate with educational programming.
- Emphasis on a layered, zone-appropriate design for sun exposure.

Soil and Irrigation:

- Savage recommended excavating and replacing ~12" of soil to ensure safe conditions for edible plants.
- Area is already irrigated; minor expansion of irrigation lines would be needed.
- Suggested organic maintenance to avoid contamination risks.

Containment Strategies for Invasive Species:

- Copper-impregnated fabric, buried metal flashing, and strategic placement to prevent spread of raspberries.

Gate Proposal:

- Gate installation proposed at one end of the path.

- The Wayzata Garden Club expressed interest in funding the gate, potentially using existing posts to reduce costs.

Board Discussion & Feedback:

- Strong support for the garden concept and educational tie-in with the library.
- Staff will return with refined cost estimates and proposed materials for pathway and garden design at a future meeting.

b. Klapprich Park Update: The Board discussed various aspects of the Klapprich Park project.

Fire Suppression System at Warming House

- Staff noted that a fire suppression system is required due to city ordinance for buildings over 2,000 sq ft; Warming House expanded from 1,600 to 2,300 sq ft.
- Estimated cost: ~\$100,000.
- Alternative systems (e.g., tank-based) did not meet code requirements.
- Building permit process is ongoing with the contractor and architect.
- Construction expected to begin mid-August, with the goal to meet the December completion deadline.

Zip Line Discussion

- The zip line has been removed from the current scope but could be reconsidered via CIP or a future phase.
- Estimated cost: ~\$40,000.
- The area for the zip line is just east of the approved play container which does not require any additional tree removal.
- The Board expressed general interest in reconsidering in a future master plan revision.

Construction and Site Work Update

- Site grading, retaining wall installation, Minnetonka Avenue sidewalk installation, and utility work are ongoing.
- Hockey rink boards were removed for drain tile installation and were put back.

- The Board discussed and suggested adding fencing or portable backstops for hockey puck control.

City Council Workshop – Klapprich Park Discussion Preparation

- Workshop is scheduled for Wednesday, August 6 at 5:45 PM.
- Noted as a regular Council workshop open to the public.
- Plan to prepare a presentation to:
 - Recontextualize the project goals and history for the council and the neighborhood.
 - Emphasize original intent: not a regional Disneyland, but a thoughtfully designed natural park.
 - Acknowledge trade-offs (e.g., loss of zip line, additional fire system cost).

Project Philosophy:

- Klapprich Park’s full renovation was clearly directed by the City Council.
- The site is classified as a community/city park (not purely neighborhood or regional), per the Master Plan.

Intended Users:

- The park is designed for more than just the adjacent or nearby homes; it’s intended to serve ~4,000+ city residents.
- Acknowledged that neighbor concerns are important, but they must be balanced against broader community needs.

ADA Compliance & Playground Relocation:

- One key reason for relocating the playground is ADA accessibility. The old location did not meet current requirements.
- Despite a few neighbors wishing it had stayed in the same spot, ADA compliance and tree impact considerations necessitated the move.
- Not a discretionary change — this is a regulatory requirement.
- Slide and stair configuration options discussed:
 1. Maintain current placement.
 2. Modify design (e.g., screen hedges, zig-zag stairs).
 3. Move east (more costly).
 4. Remove entirely.
- Noted: Slide is already custom-manufactured and cannot be returned or repurposed.

Parking Concerns

- Primary sentiment:
 - No immediate action is recommended — wait and observe.
 - Avoid reacting to projected issues that haven't materialized yet.
- Neighbors worry about increased traffic and school-related parking overflow.
- However, removing parking (e.g., "No Parking" zones) may cause greater problems, including for school pickup/drop-off and neighborhood use.

Long-term suggestion:

- If traffic becomes a proven issue post-opening, revisit with data.
- Mayor is already planning to address school parking conflicts with school district leaders.

Trees & Slope Screening

- There was a general agreement that more trees are a positive solution, especially larger coniferous trees to provide immediate screening.
- The idea of spading in mature trees was discussed as a practical and visually effective way to address concerns from nearby homeowners.
- Some concerns exist about costs and grading needed to support the plantings. A retaining wall might be necessary to stabilize the slope and improve tree health.
- There is uncertainty around what specific type of grading solution is required and what the cost implications are. WSB will be consulted to help assess feasibility.
- There is a subjective conversation around security – whether added trees improve or worsen perceived safety. This remains unresolved, as perceptions vary greatly

Slide & Stairs Debate

- Four options were proposed for the slide and stairs configuration:
 - Keep as is (slide and stairs in current location, long and straight).

- Keep the location, but modify (e.g., hedge screening, zig-zag stairs, shorten slide).
- Move stairway and play equipment east (revisit old concept — more isolated, but more expensive).
- Remove stairs and possibly the slide (which affects accessibility and connectivity).
- Important context: The slide has already been manufactured as a custom piece. It cannot be returned, changed, or repurposed. This limits flexibility and creates a sunk cost if not used.
- The underlying neighborhood concerns were discussed significantly with each of these options.
- While neighborhood concerns are framed as trees/traffic/safety, the core issue may be discomfort with increased usage and visibility.
- Group agreed that:
 - It's essential to acknowledge neighborhood input, but City parks are meant to serve the whole community, and that purpose must remain central.

Cost and Feasibility

- Moving the slide/stairs to the east would cost approximately \$200,000 more, due to grading, sidewalk, and landscape changes.
- Original move away from the east side was driven by:
 - Cost savings
 - Limited functional connectivity (not useful for playground traffic)
 - Desire to keep sight lines between play areas for safety reasons
 - Reduced tree removal
 - Reduced impervious surface

Final Discussion Summary

- Motion passed: The Parks and Trails Board officially recommends that City Council:
 - Proceed with the current plan as designed and already underway.
 - Add more trees where feasible, but without needing significantly more grading.
- Motion by Cameron, seconded by Erard. Motion passed 4-1 (Schalkle). Schalkle noted the opposing vote was not opposing the recommended option, but wanted more options teed up for Council.

c. Wayzata Beach and Little Beach Master Plan Discussion: This item was tabled to a future Board meeting.

d. Maple Tree Tapping: Staff noted that the same agreement that was created for the Maple Tree Tapping Program in 2025 will be planned for in 2026 with former Board Member Babcock. The cost associated with this program will also be included in the upcoming budget discussions with Council.

6. New Business

7. Other Business

a. Staff Updates: Staff noted that items for Sunday Music in the Park have been finalized so everything is set for the first concert on August 3.

8. Adjourn: Motion to adjourn by Chair Schalkle, seconded by Showalter. Motion passed unanimously.



Parks and Trails Board Workshop Minutes
Tuesday, July 24, 2025
Wayzata Beach and Shaver Park

Attendees: Chair Tory Schalkle, Sarah Randolph, JP Yorro, and Christian Erard.

Staff: Nick Kieser, Parks and Environment Planner

1. **Call to Order and Roll Call:** Meeting was called to order at 5:30 PM by Chair Schalkle.

2. **Wayzata Beach and Shaver Park Site Visit:** The Parks and Trails Board toured Wayzata Beach and Shaver Park to review the park and discussed any potential future changes in regards to the Parks and Trails Master Plan. The Board had the following comments:

Shaver Park

- Remove the volleyball court and let that area regrow since maintenance and drainage are significant issues. The court is not heavily used by the community.
 - The Board could send out a community poll to ensure the court should be removed.
- The Parks and Trails Master Plan calls for a large, lockable kayak system near the volleyball court. Staff and the Board noted that there are already rental kayak options near the beach. The rental racks are not full so there is not a high demand for those racks. Therefore, there is not a need for additional kayak options.
- Potentially add a hammock/s on the west side.
- Do not change the rest of the park since it should be quiet and natural.

Wayzata Beach

- The Board discussed the drainage pipe that drains water from the playground area to the beach. Board noted that the kids like to play with the water draining, so it would be beneficial to 1) add messaging to the pipe noting that

it is clean water and/or 2) add something that makes the pipe seem more intentional and thoughtful instead of a pipe jutting out of the ground.

- One thought was to add specific play equipment that incorporates the water.
- Fix the water sprayer equipment to mitigate the pooling under the swings.
 - Staff will determine if the water pressure can be reduced and/or the sprayer time shortened in between presses.
- Potentially add a sign at front of the beach concessions that notes “Shower Around Back”.
- Potentially remove QR code sign near the beach.
- Potentially add/order more Adirondack chairs.

3. Adjourn.



**City of Wayzata
Parks and Trail Board
Agenda Report**

MEETING DATE: August 12, 2025	AGENDA ITEM: 5.a
TITLE: Klapprich Park Update	
PROPOSED MOTION: N/A	
PREPARED BY: Nick Kieser, Parks and Environment Planner	
REVIEWED BY:	

ACTION REQUESTED:

N/A

FINANCIAL OR BUDGET CONSIDERATION:

N/A

2024-2026 STRATEGIC PLAN PRIORITIES RELEVANCE:

N/A

BACKGROUND:

City Council Workshop

The City Council held a workshop discussion regarding neighborhood concerns about the Klapprich Park project. Staff and the Board can discuss this workshop discussion at the meeting. The main takeaway of that discussion is to continue with the approved plan, but add additional landscaping to the hillside north of the play container and above the hillside stairs and slide.

Schedule Update

The playground equipment is planned to be shipped in different stages, but the installation of the equipment is scheduled for mid-October.

The warming house building permit is still under review. The proposed change order for the fire suppression system is scheduled to be reviewed by the City Council at their August 19 meeting. The building permit cannot be approved until after that change order is approved.

Staff can provide any additional updates on the site improvements schedule at the meeting.

Fireplace

HCM has provided options for the Board to review in regards to the fireplace in the warming house. Mainly, the Board can note their preference on the log options (if desired), base materials, lighting colors, and glass material. More information on these options can be seen in the attachments.

ATTACHMENTS:

1. Fireplace Information
2. Fireplace Options



SUBMITTAL COVER SHEET

TO: HCM
Attn: Approver

August 6th, 2025

JOB: Klapprich Warming House

Submitted Item: Manufactured Gas Fireplace

Manufacture:

Spec. Section: 10 30 50

Article:

Paragraph:

Subparagraph:

Product Description:

Product Data

SHOP DRAWING SUBMITTAL REVIEW	
<small>THIS REVIEW IS FOR GENERAL CONFORMANCE WITH PLANS AND SPECIFICATIONS ONLY. APPROVALS ARE SUBJECT TO SUBCONTRACTORS PERFORMANCE WITHIN THE CONFINES OF THE CONTRACT DOCUMENTS. REVIEW OF DIMENSIONS WILL NOT SERVE TO RELIEVE THE SUBCONTRACTOR OF CONTRACTUAL RESPONSIBILITY FOR ANY DEVIATION FROM THE CONTRACT REQUIREMENTS.</small>	
<input type="checkbox"/> MAKE CORRECTIONS NOTED	<input checked="" type="checkbox"/> REVIEWED
<input type="checkbox"/> FIELD MEASUREMENTS OR TEMPLATES REQUIRED PRIOR TO FABRICATION	<input type="checkbox"/> NOT APPROVED- REVISE AND RESUBMIT
EBERT, INC. 23350 COUNTY ROAD 10, LORETTO, MN 55357 763.498.7844 / 763.498.9951 FAX	
BY <u>Taylor Havlik</u>	DATE <u>08/06/2025</u>

Primoll

DIRECT VENT GAS FIREPLACES

HEAT & GLO



Primo II

Create a place you look forward to each day—and can enjoy in any season or climate. At its heart is the Primo II luxury linear gas fireplace. Tailor the look to fit your decor. Choose low or no heat. Kick back with family or friends at a time when rest and rejuvenation have never been more important.



The clean face design of Primo II brings out big flames in an opening that's a full 18" tall, with 48", 60" or 72" single or double-sided designs. View the same beautiful fire from your living room and patio with our indoor/outdoor kit. And craft your look with a choice of crushed glass, logs and interior panels that blend beautifully whether your home is modern or transitional.

With heat control, you can bring combustible materials up to the fireplace opening and place your TV or artwork just inches above it, while SafeSurface™ glass protects little hands with no need for a screen.



See it burn!



PRIMO II 72 double-sided with indoor/outdoor kit, shown with Stone Column interior panels and Birch logs

PRODUCT DETAILS

- Tall 18" viewing height for generous view of flickering flames
- 48", 60" and 72" wide in one-sided or double-sided models
- Safely install combustible materials up to the fireplace opening
- Multi-colored LED ember lighting highlights crushed glass
- Five interior panel styles and three log designs for a custom look
- SafeSurface glass keeps hands safe without a safety screen
- Easy control with touchscreen remote, wireless wall switch, app or voice control
- Cool-wall technology enables installation of TV or artwork overhead
- Optional automatic heat distribution in your space for warmth when it's wanted
- Optional indoor/outdoor kit for double-sided application

SINGLE-SIDED

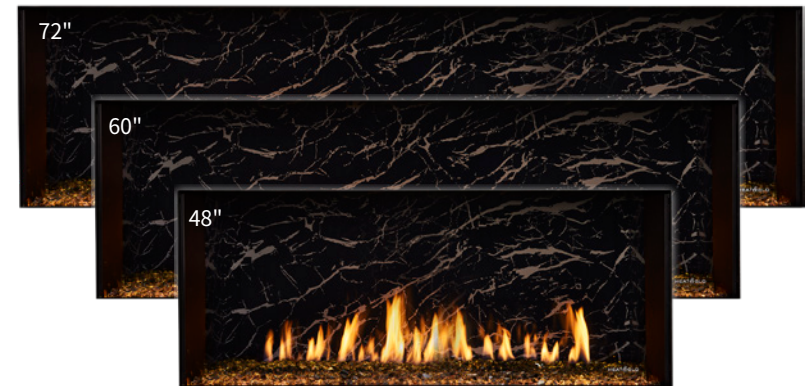

DOUBLE-SIDED





Primo II 48 shown with Stone Column interior panels and crystal glass media

INTERIOR OPTIONS



Optional decorative logs customize each fireplace for a unique design. Each set elevates the realism by arching over the flames for a true interaction with the fire.

FIVE INTERIOR PANEL OPTIONS - ONE SELECTION IS REQUIRED



STONE COLUMN



ARCHITECTURAL

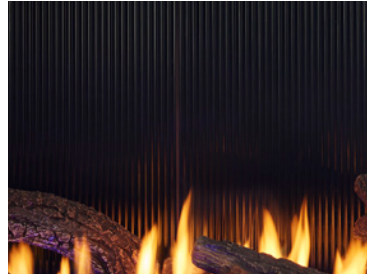

FLUTED BLACK GLASS



MARBLE BLACK GLASS < two-sided panel >



REFLECTIVE BLACK GLASS

THREE LOG SETS - OPTIONAL SELECTION - NOTE: CANNOT BE COMBINED WITH RIVER ROCK STONES MEDIA



BIRCH



DRIFTWOOD



OAK

FOUR CRUSHED GLASS COLORS + RIVER ROCK STONES - ONE SELECTION IS REQUIRED



CRYSTAL GLASS

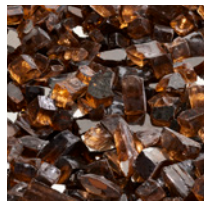

COPPER GLASS

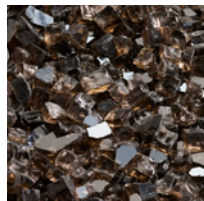

SMOKED GLASS



GRAPHITE GLASS

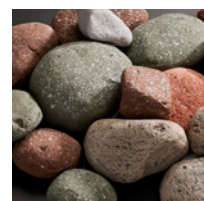

RIVER ROCK STONES

NOTE
RIVER ROCK STONES
CANNOT BE COMBINED
WITH ANY LOG SET

SEVEN LED EMBER BED LIGHTING COLORS - INCLUDED AS STANDARD



WHITE LIGHT



AQUA LIGHT



BLUE LIGHT

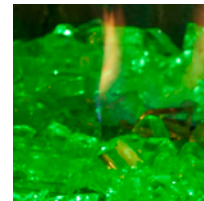

GREEN LIGHT



ORANGE LIGHT



RED LIGHT



MAGENTA LIGHT

POWERFLOW™ II TECHNOLOGY



Our exclusive PowerFlow II technology redirects the flow of heat to the outside of the home to keep outer glass temperatures safe and maintain a cool wall, enabling you to add a TV or heat-sensitive materials just inches above your fireplace.

Although the Primo II is specifically designed for no heat, an optional heat management system (PRIMO-HEAT-DUCT) may be utilized to capture a low amount of heat. This heat can be transferred into the same room or directed to another area of the home up to 25 feet away.

A STANDARD POWERFLOW II



B OPTIONAL PRIMO-HEAT-DUCT

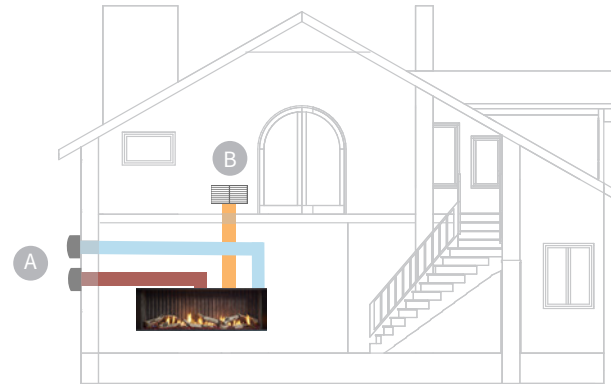

- AIR INTAKE*
- EXHAUST
- OPTIONAL PRIMO-HEAT-DUCT

*The air intake may be vertically terminated however, vertical inlet caps are not available from Hearth & Home Technologies. Please refer to the installation manual for minimum effective cap opening.

PRIMO II TECHNOLOGIES



INTELLIFIRE TOUCH® TECHNOLOGY

IntelliFire Touch is our most advanced intermittent-pilot ignition (IPI) system, making running your appliance simple, smart and safe. Utilize the included touchscreen remote control or add a wireless wall switch or IntelliFire® app for the solution that fits your lifestyle.



MULTI-COLORED LED LIGHTING TECHNOLOGY

Superior performance and extended efficiency. This technology supplies high-contrast, brilliant lighting to accentuate the flames. Can be used as mood lighting with or without the flames. Able to control the lighting with the included touchscreen remote (RC450).



DIRECT VENT TECHNOLOGY

Direct Vent fireplaces remove 100% of combustion exhaust and odors outside of the home. These sealed fireplaces provide optimal heat, conserve energy and ensure clean, safe indoor air quality.



SAFESURFACE GLASS

SafeSurface glass keeps hands safe without the need for a safety screen thanks to double-pane glass and internal cooling technology.

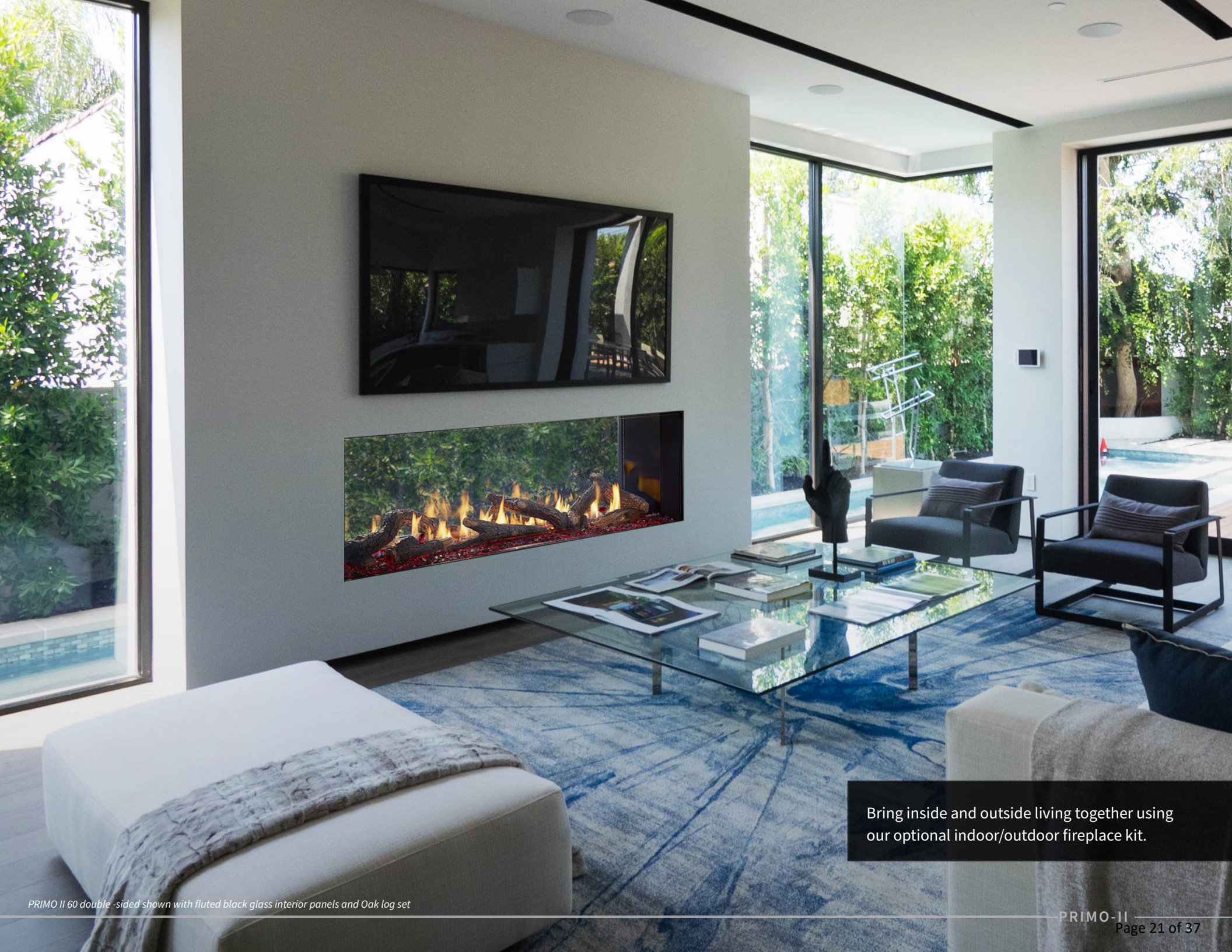

Bring inside and outside living together using our optional indoor/outdoor fireplace kit.

CONTROLS

INTELLIFIRE APP

All the features of a remote control with an app installed on your smart device. Monitor your fire from anywhere or even control it with the sound of your voice.



IntelliFire is compatible with voice assistants Amazon Alexa and Google Assistant. Only select features are available on the app.

TOUCHSCREEN REMOTE

Features: on/off, flame height adjustment, lights adjustment, child lock, timer mode, wall docking station.



WIRELESS WALL SWITCH

Features: on/off, battery strength indicator.



PRIMO II SPECIFICATIONS

MODEL	WIDTH		HEIGHT		DEPTH		GLASS SIZE	BTU/HOUR INPUT
	UNIT	FRAMING	UNIT	FRAMING	UNIT	FRAMING		
PRIMO-II-48, PRIMO-II-48ST	64-3/8" [1635]	66-3/4" [1695]	40-13/16" [1037]	45" [1143]	18-1/4" [464]	18" [457] ST: 17" [432]	48" x 18" [1219 X 457]	31,500 - 45,000 BTUs (NG) 31,000 - 42,000 BTUs (LP)
PRIMO-II-60, PRIMO-II-60ST	76-3/8" [1940]	78-3/4" [2000]	40-13/16" [1037]	45" [1143]	18-1/4" [464]	18" [457] ST: 17" [432]	60" x 18" [1524 X 457]	39,500 - 57,000 BTUs (NG) 36,500 - 50,000 BTUs (LP)
PRIMO-II-72, PRIMO-II-72ST	88-3/8" [2245]	90-3/4" [2305]	40-13/16" [1037]	45" [1143]	18-1/4" [464]	18" [457] ST: 17" [432]	72" x 18" [1829 x 457]	42,000 - 58,500 BTUs (NG) 40,500 - 55,000 BTUs (LP)

MODEL	A	B	C	D	E
PRIMO48, PRIMO48ST	64-3/8" [1635]	54-3/16" [1375]	44-5/8" [1134]	48" [1219]	67-3/16" [1707]
PRIMO60, PRIMO60ST	76-3/8" [1940]	60-3/16" [1529]	56-5/8" [1438]	60" [1524]	79-3/16" [2011]
PRIMO72, PRIMO72ST	88-3/8" [2245]	66-3/16" [1681]	68-5/8" [1743]	72" [1829]	91-3/16" [2316]

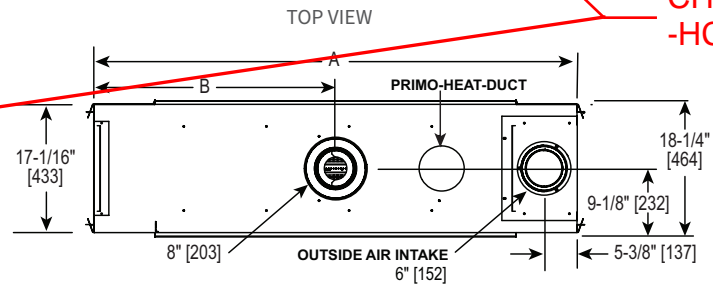

**CHOSEN MODEL
-HCM**

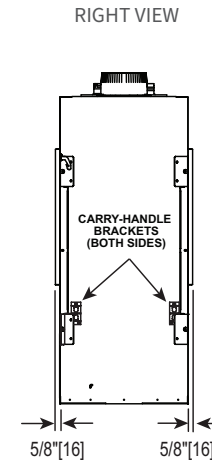
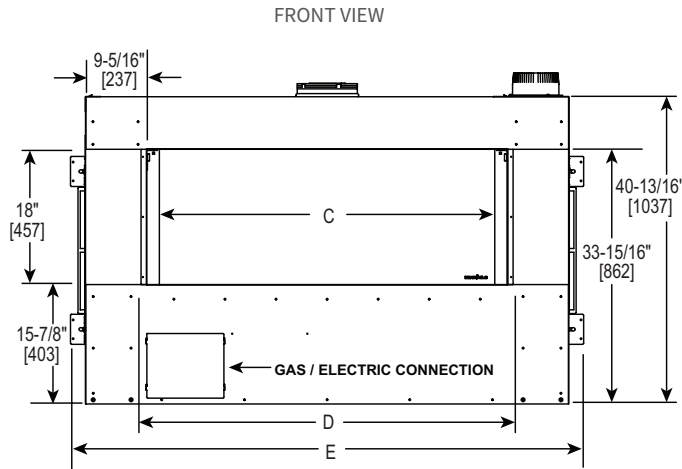
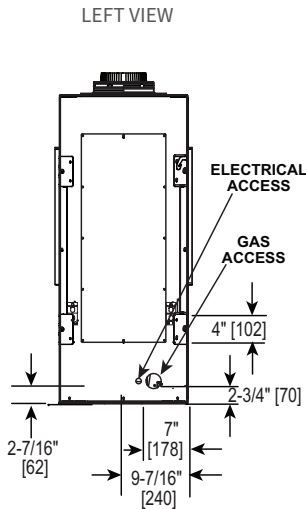

Dimensions are in inches and millimeters. Product information is not complete and is subject to change without notice. Product installation must adhere strictly to instructions shipped with product. We recommend measuring individual units at installation. Assumes the use of 1/2" sheetrock. NOTE: Combustible material should not cover the face.

Refer to installation manual for detailed specifications on installing this product. Heat & Glo® reserves the right to update units periodically. The flame and ember appearance may vary based on the type of fuel burned and the venting configuration used. Actual product appearance, including flame, may differ from product images.



PRIMO II 72 double-sided, shown with Architectural interior panels and Driftwood logs

For complete information on this model, please contact us at:



OUR SUSTAINABILITY STORY

Our history of leadership in the hearth industry compels us to now lead the way in developing manufacturing practices that ensure our planet remains as durable, beautiful and long-lasting as our products. Find out how we are leading the industry in sustainable practices by scanning the code.

LIMITED LIFETIME WARRANTY

The strongest in the industry, Heat & Glo® provides a limited lifetime warranty on the most important aspects: firebox and heat exchanger. For full warranty details, visit heatnglo.com

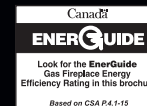

HEAT & GLO

No one builds a better fire

heatnglo.com
 (888) 427-3973 (952) 985-6000
info@heatnglo.com

[facebook.com/HeatandGlo](https://www.facebook.com/HeatandGlo)
x.com/HeatandGlo
[youtube.com/HeatandGlo](https://www.youtube.com/HeatandGlo)

HNG-1144U-0424

Chose one, two sided fireplace

FIVE INTERIOR PANEL OPTIONS - ONE SELECTION IS REQUIRED



STONE COLUMN



ARCHITECTURAL

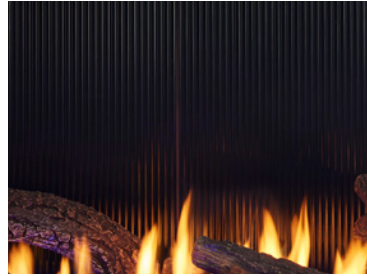

FLUTED BLACK GLASS



MARBLE BLACK GLASS <two-sided panel>



REFLECTIVE BLACK GLASS

THREE LOG SETS - OPTIONAL SELECTION - NOTE: CANNOT BE COMBINED WITH RIVER ROCK STONES MEDIA



BIRCH



DRIFTWOOD



OAK

FOUR CRUSHED GLASS COLORS + RIVER ROCK STONES - ONE SELECTION IS REQUIRED



CRYSTAL GLASS

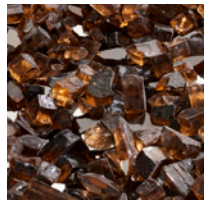

COPPER GLASS

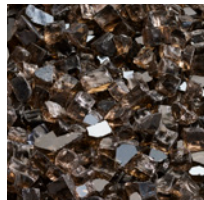

SMOKED GLASS



GRAPHITE GLASS

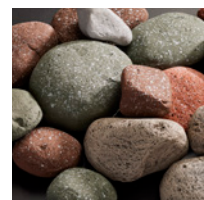

RIVER ROCK STONES

NOTE
RIVER ROCK STONES
CANNOT BE COMBINED
WITH ANY LOG SET

SEVEN LED EMBER BED LIGHTING COLORS - INCLUDED AS STANDARD



WHITE LIGHT



AQUA LIGHT



BLUE LIGHT

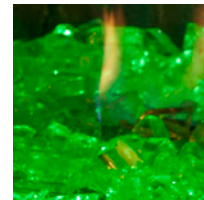

GREEN LIGHT



ORANGE LIGHT



RED LIGHT



MAGENTA LIGHT



City of Wayzata Parks and Trail Board Agenda Report

MEETING DATE: August 12, 2025	AGENDA ITEM: 5.b
TITLE: Wayzata Beach/Shaver Park and Little Beach Master Plan Discussion	
PROPOSED MOTION: N/A	
PREPARED BY: Nick Kieser, Parks and Environment Planner	
REVIEWED BY:	

ACTION REQUESTED:

N/A

FINANCIAL OR BUDGET CONSIDERATION:

N/A

2024-2026 STRATEGIC PLAN PRIORITIES RELEVANCE:

N/A

BACKGROUND:

The Board expressed interest in reviewing the information in the Parks and Trails Master Plan for each park to assess whether updates are needed. These discussions will also help determine whether the Parks and Trails Master Plan should be updated and identify priority areas for future improvements. The link below provides access to the Parks and Trails Master Plan. At this meeting, the Board can review and discuss the plans for Wayzata Beach/Shaver Park and Little Beach.

[Parks and Trails Master Plan](#)

ATTACHMENTS:

None

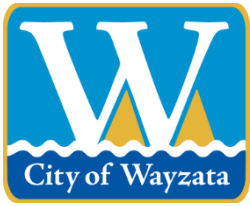

City of Wayzata Parks and Trail Board Agenda Report

MEETING DATE: August 12, 2025	AGENDA ITEM: 5.c
TITLE: Sunday Music in the Park Concerts Review	
PROPOSED MOTION: N/A	
PREPARED BY: Nick Kieser, Parks and Environment Planner	
REVIEWED BY:	

ACTION REQUESTED:

N/A

FINANCIAL OR BUDGET CONSIDERATION:

N/A

2024-2026 STRATEGIC PLAN PRIORITIES RELEVANCE:

N/A

BACKGROUND:

The first two Sunday Music in the Park concerts have been completed. Westwind Swing Band played on August 3, and Jimmi and the Band of Souls played on August 10. The Parks and Trails Board can review these concerts and determine if anything needs to change for the remaining two concerts.

ATTACHMENTS:

None



City of Wayzata Parks and Trail Board Agenda Report

MEETING DATE: August 12, 2025	AGENDA ITEM: 6.a
TITLE: CIP Budget Discussion	
PROPOSED MOTION: N/A	
PREPARED BY: Nick Kieser, Parks and Environment Planner	
REVIEWED BY:	

ACTION REQUESTED:

N/A

FINANCIAL OR BUDGET CONSIDERATION:

N/A

2024-2026 STRATEGIC PLAN PRIORITIES RELEVANCE:

N/A

BACKGROUND:

The Parks and Trails Board can review and discuss the attached Parks and Trails Board CIP. Council will discuss the CIP this fall to finalize the CIP in December. Any comments or proposed changes can be included in any of the Council discussions.

ATTACHMENTS:

1. 2026-2035 CIP

Parks and Trails Improvement Fund #404

CAPITAL PROJECT SUMMARY

Estimated Cost (with Inflation)

Project Year	Project	Current Cost	2024	2025	2026	2027	2028	2029	2030	2031	2032	2033	2034	2035	Other Funding Source	Other Funding Source Amount
2024	Little Woods Improvements	5,400	5,200	-	-	-	-	-	-	-	-	-	-	-	-	-
2024	Planting, Removal, & Maintenance of City Trees (EAB Management)	82,400	80,000	-	-	-	-	-	-	-	-	-	-	-	-	-
2024	Reconstruction of Wayzata Middle School Tennis Courts	158,800	154,200	-	-	-	-	-	-	-	-	-	-	-	Miscellaneous	77,100
2024	Klapprich Park Design Development and Construction Documents	159,700	155,000	-	-	-	-	-	-	-	-	-	-	-	-	-
2024	Reconstruction of Bell Tennis Court	339,500	329,600	-	-	-	-	-	-	-	-	-	-	-	Miscellaneous	100,000
2025	Miscellaneous Plantings	20,600	-	20,600	-	-	-	-	-	-	-	-	-	-	-	-
2025	Planting, Removal, & Maintenance of City Trees (EAB Management)	80,000	-	80,000	-	-	-	-	-	-	-	-	-	-	-	-
2025	Klapprich Park Improvements	2,687,000	-	2,073,041	-	-	-	-	-	-	-	-	-	-	TIF	140,198
2026	City Hall Addition of gate and path	12,600	-	-	13,000	-	-	-	-	-	-	-	-	-	-	-
2026	Wrought iron fence maintenance - Children's Garden	16,300	-	-	16,800	-	-	-	-	-	-	-	-	-	-	-
2026	Wrought iron fence maintenance - Heritage Park	25,800	-	-	26,600	-	-	-	-	-	-	-	-	-	-	-
2026	Wrought iron fence maintenance - Post Office Park	25,800	-	-	26,600	-	-	-	-	-	-	-	-	-	-	-
2026	Heritage Addition of lounge seating, tables and chairs (4), picnic game area	27,400	-	-	28,200	-	-	-	-	-	-	-	-	-	-	-
2026	Planting, Removal, & Maintenance of City Trees (EAB Management)	77,700	-	-	80,000	-	-	-	-	-	-	-	-	-	-	-
2026	Shaver Park Design Development and Construction Documents	109,300	-	-	112,600	-	-	-	-	-	-	-	-	-	-	-
2026	Planting, Removal, & Maintenance of City Trees (EAB Management)	75,400	-	-	-	80,000	-	-	-	-	-	-	-	-	-	-
2027	Beach+Shaver Park Improvements: Shade structure, hammock/art poles, picnic plaza, parking lot, volleyball courts, park building renovation, fire place	527,100	-	-	-	559,200	-	-	-	-	-	-	-	-	-	-
2028	City Hall Addition of game cart	5,400	-	-	-	-	5,900	-	-	-	-	-	-	-	-	-
2028	Broadway Stairway Renovation of lighting	50,000	-	-	-	-	54,600	-	-	-	-	-	-	-	-	-
2028	Wayfinding Signage Study	57,400	-	-	-	-	62,700	-	-	-	-	-	-	-	-	-
2028	Planting, Removal, & Maintenance of City Trees (EAB Management)	73,200	-	-	-	-	80,000	-	-	-	-	-	-	-	-	-
2029	Eastman Ln Addition of interpretive signage	9,300	-	-	-	-	-	10,500	-	-	-	-	-	-	-	-
2029	Klapp+Bell Restriping and resurfacing of (4) pickleball (includes expansion of courts)	46,400	-	-	-	-	-	52,200	-	-	-	-	-	-	-	-
2029	Wayfinding Signs - Park Signage	50,700	-	-	-	-	-	57,100	-	-	-	-	-	-	-	-
2029	Planting, Removal, & Maintenance of City Trees (EAB Management)	71,100	-	-	-	-	-	80,000	-	-	-	-	-	-	-	-
2029	Eastman Ln Addition of trail and boardwalk	184,400	-	-	-	-	-	207,500	-	-	-	-	-	-	-	-
2030	Community Garden Fencing	11,200	-	-	-	-	-	-	13,000	-	-	-	-	-	-	-
2030	Community Gardens Initial Install	45,000	-	-	-	-	-	-	52,200	-	-	-	-	-	-	-
2030	Planting, Removal, & Maintenance of City Trees (EAB Management)	69,100	-	-	-	-	-	-	80,100	-	-	-	-	-	-	-
2030	Resurface Wayzata Middle School Tennis Courts (includes replacement of net posts)	45,700	-	-	-	-	-	-	-	54,600	-	-	-	-	-	-
2031	Planting, Removal, & Maintenance of City Trees (EAB Management)	67,100	-	-	-	-	-	-	-	80,100	-	-	-	-	-	-
2032	Locust Hills Park-Identify Future Needs	8,800	-	-	-	-	-	-	-	-	10,800	-	-	-	-	-
2032	Planting, Removal, & Maintenance of City Trees (EAB Management)	65,000	-	-	-	-	-	-	-	-	79,900	-	-	-	-	-
		\$ 5,290,600	\$ 724,000	\$ 2,173,641	\$ 303,800	\$ 639,200	\$ 203,200	\$ 407,300	\$ 145,300	\$ 134,700	\$ 90,700	\$ -	\$ -	\$ -	\$ -	\$ 317,298
				613,959												

Parks and Trails Improvement Fund #404

PROJECTED CASH FLOWS

	2024 Actual	2025	2026	2027	2028	2029	2030	2031	2032	2033	2034	2035
REVENUES												
Investment earnings	88,245	23,423	6,353	4,229	-	-	-	-	-	-	1,245	3,895
Charges for services	16,171	16,656	17,156	17,670	18,201	18,747	19,309	19,888	20,485	21,099	21,732	22,384
Park Dedication	95,083	-	-	-	-	-	-	-	-	-	-	-
Rental Earnings	49,851	51,346	52,886	54,473	56,107	57,790	59,524	61,310	63,149	65,044	66,995	69,005
Donations	-	220,000	-	-	-	-	-	-	-	-	-	-
Misc. Revenues	69,131	-	-	-	-	-	-	-	-	-	-	-
TOTAL REVENUES	318,480	311,425	76,395	76,372	74,308	76,537	78,833	81,198	83,634	86,143	89,973	95,284
EXPENDITURES												
Capital Outlay	413,368	2,173,641	303,800	639,200	203,200	407,300	145,300	134,700	90,700	-	-	-
TOTAL EXPENDITURES	413,368	2,173,641	303,800	639,200	203,200	407,300	145,300	134,700	90,700	-	-	-
EXCESS (DEFICIENCY) OF REVENUES OVER (UNDER) EXPENDITURES	(94,887)	(1,862,215)	(227,405)	(562,828)	(128,892)	(330,763)	(66,467)	(53,502)	(7,066)	86,143	89,973	95,284
OTHER FINANCING (USES) AND SOURCES												
Prepaid Costs from Prior Year	-	-	-	-	-	-	-	-	-	-	-	-
Proceeds from TIF	-	140,198	-	-	-	-	-	-	-	-	-	-
Other project funding revenue	185,994	-	-	-	-	-	-	-	-	-	-	-
Transfer - 2009 Street and Big Woods Bond Issuance excess	-	-	-	-	-	-	-	-	-	-	-	-
Transfer In - Excess Reserves	826,099	-	-	-	-	-	-	-	-	-	-	-

Transfer In - Marina Fund	-	15,000	15,000	15,000	50,000	100,000	100,000	150,000	175,000	175,000	175,000	175,000
Transfer In - Tree and Planting Fund												
TOTAL OTHER FINANCING SOURCES (USES)	1,012,093	155,198	15,000	15,000	50,000	100,000	100,000	150,000	175,000	175,000	175,000	175,000
NET CHANGE IN FUND BALANCES	917,206	(1,707,018)	(212,405)	(547,828)	(78,892)	(230,763)	33,533	96,498	167,934	261,143	264,973	270,284
FUND BALANCES, JANUARY 1	\$ 1,425,101	\$ 2,342,309	\$ 635,291	\$ 422,886	\$ (124,941)	\$ (203,833)	\$ (434,596)	\$ (401,063)	\$ (304,565)	\$ (136,631)	\$ 124,513	\$ 389,485
FUND BALANCES, DECEMBER 31	\$ 2,342,309	\$ 635,291	\$ 422,886	\$ (124,941)	\$ (203,833)	\$ (434,596)	\$ (401,063)	\$ (304,565)	\$ (136,631)	\$ 124,513	\$ 389,485	\$ 659,769

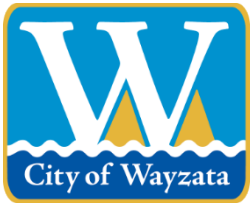

City of Wayzata Parks and Trail Board Agenda Report

MEETING DATE: August 12, 2025	AGENDA ITEM: 7.a
TITLE: Communications Recap	
PROPOSED MOTION: N/A	
PREPARED BY: Nick Kieser, Parks and Environment Planner	
REVIEWED BY: Mike Kelly, Interim City Manager	

ACTION REQUESTED:

N/A

FINANCIAL OR BUDGET CONSIDERATION:

N/A

2024-2026 STRATEGIC PLAN PRIORITIES RELEVANCE:

N/A

BACKGROUND:

The Board can discuss anything that needs to be passed through City channels in the near future.

ATTACHMENTS:

None



City of Wayzata Parks and Trail Board Agenda Report

MEETING DATE: August 12, 2025	AGENDA ITEM: 7.b
TITLE: Staff Updates	
PROPOSED MOTION: N/A	
PREPARED BY: Nick Kieser, Parks and Environment Planner	
REVIEWED BY: Mike Kelly, Interim City Manager	

ACTION REQUESTED:

N/A

FINANCIAL OR BUDGET CONSIDERATION:

N/A

2024-2026 STRATEGIC PLAN PRIORITIES RELEVANCE:

N/A

BACKGROUND:

City Hall Park/Children's Garden - The Parks Department is still in the process of getting an updated plan and cost estimates for the proposed plan that was discussed at the last Parks and Trails Board meeting. More information is planned to be discussed at the September Board meeting.

ATTACHMENTS:

None

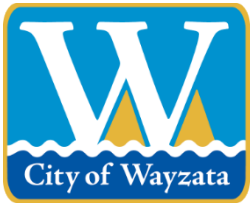

City of Wayzata Parks and Trail Board Agenda Report

MEETING DATE: August 12, 2025	AGENDA ITEM: 7.c
TITLE: Future Agenda Items	
PROPOSED MOTION: N/A	
PREPARED BY: Nick Kieser, Parks and Environment Planner	
REVIEWED BY: Mike Kelly, Interim City Manager	

ACTION REQUESTED:

N/A

FINANCIAL OR BUDGET CONSIDERATION:

N/A

2024-2026 STRATEGIC PLAN PRIORITIES RELEVANCE:

N/A

BACKGROUND:

The Board can discuss any agenda items that they would like to add to upcoming agendas for discussion.

ATTACHMENTS:

None



City of Wayzata Parks and Trail Board Agenda Report

MEETING DATE: August 12, 2025	AGENDA ITEM: 8.a
TITLE: Next Meeting - September 17	
PROPOSED MOTION:	
PREPARED BY: Nick Kieser, Parks and Environment Planner	
REVIEWED BY: Mike Kelly, Interim City Manager	

ACTION REQUESTED:

FINANCIAL OR BUDGET CONSIDERATION:

2024-2026 STRATEGIC PLAN PRIORITIES RELEVANCE:

BACKGROUND:

The next Parks and Trails Board Meeting is scheduled for September 17. The 2025 City Calendar is attached.

ATTACHMENTS:

1. Wayzata Parks and Trails Board Minute Taking Schedule
2. Wayzata Meeting Calendar 2025
3. Draft 2026 Wayzata Calendar

Wayzata Parks and Trails Board

2025 Schedule for Taking Meeting Minutes

Date	Committee Member
January 15	Staff
February 19	Jensen
March 19	Yorro
April 16	Cameron
May 21	Schalkle
June 18	Showalter
July 16	Randolph
August 20	Erard
September 17	Jensen
October 15	Yorro
November 19	Cameron
December 17	Schalkle

City of Wayzata 2025 Meeting Calendar

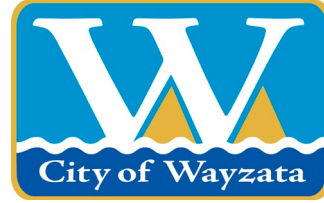

January 2025						
S	M	T	W	Th	F	S
			1	2	3	4
5	6	7	8	9	10	11
12	13	14	15	16	17	18
19	20	21	22	23	24	25
26	27	28	29	30	31	

February 2025						
S	M	T	W	Th	F	S
						1
2	3	4	5	6	7	8
9	10	11	12	13	14	15
16	17	18	19	20	21	22
23	24	25	26	27	28	

March 2025						
S	M	T	W	Th	F	S
						1
2	3	4	5	6	7	8
9	10	11	12	13	14	15
16	17	18	19	20	21	22
23	24	25	26	27	28	29
30	31					

April 2025						
S	M	T	W	Th	F	S
						1
2	3	4	5	6	7	8
9	10	11	12	13	14	15
16	17	18	19	20	21	22
23	24	25	26	27	28	

May 2025						
S	M	T	W	Th	F	S
						1
2	3	4	5	6	7	8
9	10	11	12	13	14	15
16	17	18	19	20	21	22
23	24	25	26	27	28	29
30	31					

June 2025						
S	M	T	W	Th	F	S
						1
2	3	4	5	6	7	8
9	10	11	12	13	14	15
16	17	18	19	20	21	22
23	24	25	26	27	28	29
30						

July 2025						
S	M	T	W	Th	F	S
						1
2	3	4	5	6	7	8
9	10	11	12	13	14	15
16	17	18	19	20	21	22
23	24	25	26	27	28	29
30	31					

August 2025						
S	M	T	W	Th	F	S
						1
2	3	4	5	6	7	8
9	10	11	12	13	14	15
16	17	18	19	20	21	22
23	24	25	26	27	28	29
30	31					

September 2025						
S	M	T	W	Th	F	S
						1
2	3	4	5	6	7	8
9	10	11	12	13	14	15
16	17	18	19	20	21	22
23	24	25	26	27	28	29
30						

October 2025						
S	M	T	W	Th	F	S
						1
2	3	4	5	6	7	8
9	10	11	12	13	14	15
16	17	18	19	20	21	22
23	24	25	26	27	28	29
30	31					

November 2025						
S	M	T	W	Th	F	S
						1
2	3	4	5	6	7	8
9	10	11	12	13	14	15
16	17	18	19	20	21	22
23	24	25	26	27	28	29
30						

December 2025						
S	M	T	W	Th	F	S
						1
2	3	4	5	6	7	8
9	10	11	12	13	14	15
16	17	18	19	20	21	22
23	24	25	26	27	28	29
30	31					

- Energy & Environment 5:30 PM
- Planning Commission - 6:30 PM
- City Council - 7:00 PM
Local Board of Appeal & Equalization - April 17th
- Charter Commission - 9:00 AM
- Lake Minnetonka Conservation District (LMCD)
- Heritage Preservation Board (HPB) - 11:30 AM
- Housing & Redevelopment Authority (HRA) - 7:30 AM
- Parks & Trails Board - 6:00 PM
- Night to Unite
- Holiday Observed
City Offices Closed
- Election
Precinct Caucuses - no statewide caucus in 2025

Meeting dates and times are subject to change. Dates can be confirmed by calling City Hall.

Revised
4/25/2025

City of Wayzata 2026 Meeting Calendar

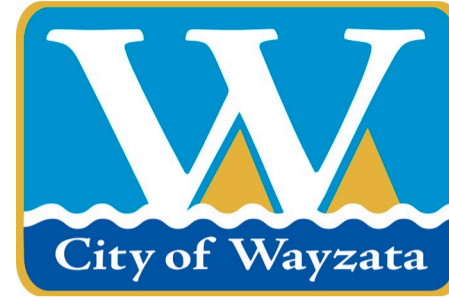

January 2026						
S	M	T	W	Th	F	S
				1	2	3
4	5	6	7	8	9	10
11	12	13	14	15	16	17
18	19	20	21	22	23	24
25	26	27	28	29	30	31

February 2026						
S	M	T	W	Th	F	S
1	2	3	4	5	6	7
8	9	10	11	12	13	14
15	16	17	18	19	20	21
22	23	24	25	26	27	28

March 2026						
S	M	T	W	Th	F	S
1	2	3	4	5	6	7
8	9	10	11	12	13	14
15	16	17	18	19	20	21
22	23	24	25	26	27	28
29	30	31				

April 2026						
S	M	T	W	Th	F	S
			1	2	3	4
5	6	7	8	9	10	11
12	13	14	15	16	17	18
19	20	21	22	23	24	25
26	27	28	29	30		

May 2026						
S	M	T	W	Th	F	S
					1	2
3	4	5	6	7	8	9
10	11	12	13	14	15	16
17	18	19	20	21	22	23
24	25	26	27	28	29	30
31						

June 2026						
S	M	T	W	Th	F	S
	1	2	3	4	5	6
7	8	9	10	11	12	13
14	15	16	17	18	19	20
21	22	23	24	25	26	27
28	29	30				

July 2026						
S	M	T	W	Th	F	S
			1	2	3	4
5	6	7	8	9	10	11
12	13	14	15	16	17	18
19	20	21	22	23	24	25
26	27	28	29	30	31	

August 2026						
S	M	T	W	Th	F	S
						1
2	3	4	5	6	7	8
9	10	11	12	13	14	15
16	17	18	19	20	21	22
23	24	25	26	27	28	29
30	31					

September 2026						
S	M	T	W	Th	F	S
		1	2	3	4	5
6	7	8	9	10	11	12
13	14	15	16	17	18	19
20	21	22	23	24	25	26
27	28	29	30			

October 2026						
S	M	T	W	Th	F	S
				1	2	3
4	5	6	7	8	9	10
11	12	13	14	15	16	17
18	19	20	21	22	23	24
25	26	27	28	29	30	31

November 2026						
S	M	T	W	Th	F	S
1	2	3	4	5	6	7
8	9	10	11	12	13	14
15	16	17	18	19	20	21
22	23	24	25	26	27	28
29	30					

December 2026						
S	M	T	W	Th	F	S
		1	2	3	4	5
6	7	8	9	10	11	12
13	14	15	16	17	18	19
20	21	22	23	24	25	26
27	28	29	30	31		

- Energy & Environment 5:30 PM
- Planning Commission - 6:30 PM
- City Council - 7:00 PM
- Local Board of Appeal & Equalization - TBD April 2026
- Charter Commission - 9:00 AM
- Lake Minnetonka Conservation District (LMCD)
- Heritage Preservation Board (HPB) - 11:30 AM
- Housing & Redevelopment Authority (HRA) - 7:30 AM
- Parks & Trails Board - 6:00 PM
- Night to Unite
- Holiday Observed
City Offices Closed
- Election
Precinct Caucuses—2/3/26 (No Public Meetings)

Meeting dates and times are subject to change. Dates can be confirmed by calling City Hall.

Revised